

TECHNICAL DATA E-PRO

Drop-in refrigerated well and cold plate



The E-Pro drop-in unit range offers all the equipment needed for a complete and effective self-service line. The top-quality units, sized to take GN containers, are compact in size and come equipped with a separate digital control panel.



GENERAL

- Products are designed for the short-term serving of cold foods and maintaining cold food temperature
- The separate control panel has a connector and is easy to install
- There are plenty of accessories available, such as different types of over shelves
- The wells have hygienic rounded corners and GN1/1 dividers as standard option

PERFORMANCE

- The digital control panel features an on/off switch and a temperature display
- The temperature can be adjusted between +2 and +15°C
- The cold well and plate product serie includes four different sizes compatible with GN 1/1 containers

TECHNICAL FEATURES

- To guarantee energy efficiency, the wells are lined with polyurethane insulation
- The units are fitted with a 3m and the control panel with a 1.5m power cord
- CFC and HCFC free
- Refrigerant R290
- All E-Pro drop-in units are CE marked



Drop-in refrigerated well

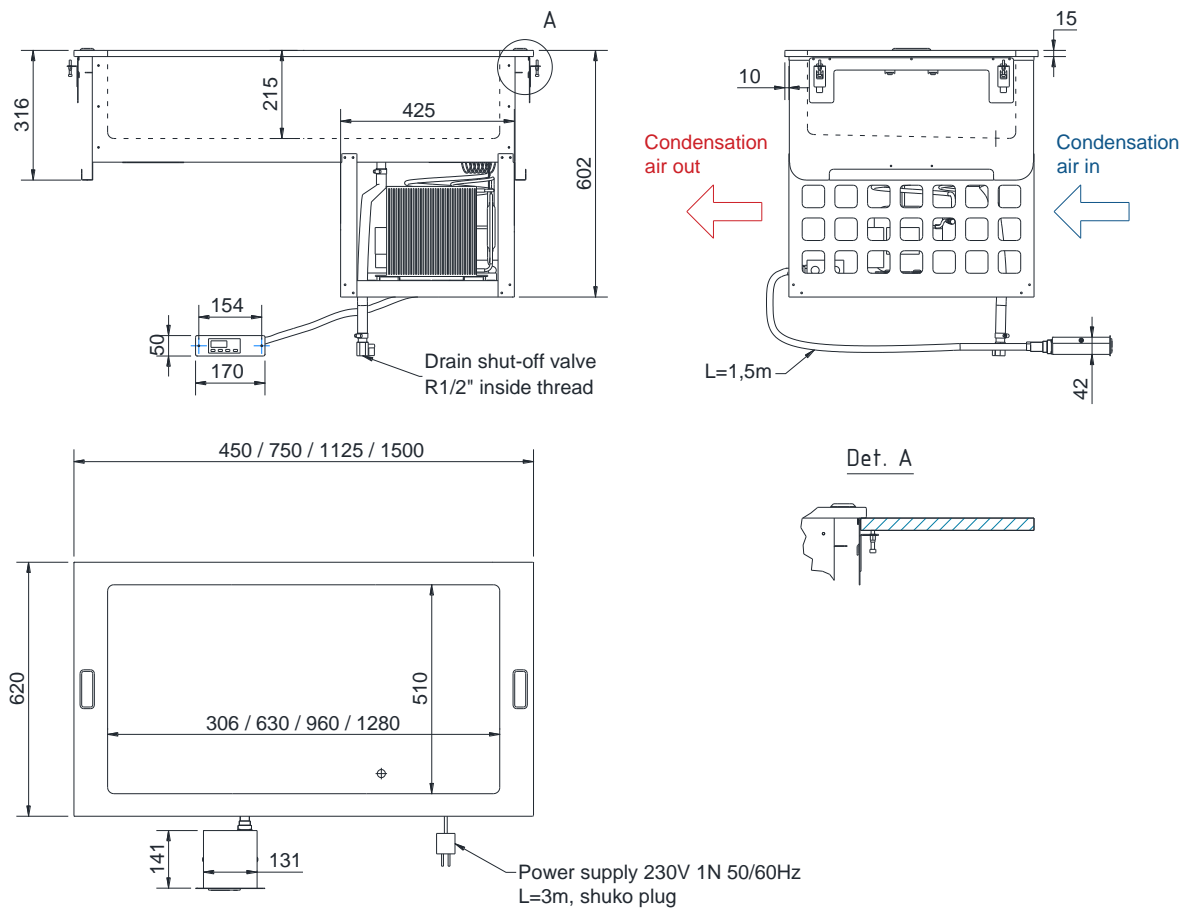

MODEL	CUT-OUT ON TABLE TOP mm
D-I 04 C	435 x 604
D-I 07 C	735 x 604
D-I 11 C	1110 x 604
D-I 15 C	1485 x 604

TECHNICAL DATA				
Model	D-I 04 C	D-I 07 C	D-I 11 C	D-I 15 C
External dimensions w x d x h mm	450x620x602	750x620x602	1125x620x602	1500x620x602
Temperature range °C	+2...+15	+2...+15	+2...+15	+2...+15
Electrical connection V, Hz	230 1N, 50/60	230 1N, 50/60	230 1N, 50/60	230 1N, 50/60
Connected load kW	0,25	0,25	0,25	0,25
Enclosure class	IP44	IP44	IP44	IP44
Type of refrigerant, charge g, GWP	R290, 100, 3	R290, 125, 3	R290, 150, 3	R290, 150, 3
tCO ² -ekv	0,00030	0,00038	0,00045	0,00045
Net weight kg	28	33	39	45
Unit volume m ³	0,3	0,5	0,7	1,0
Unit dimensions mm				
height	770	770	770	770
depth	800	800	800	800
width	480	770	1150	1530

Due to continuous product development we reserve the right to technical changes without notice.



Drop-in refrigerated cold plate

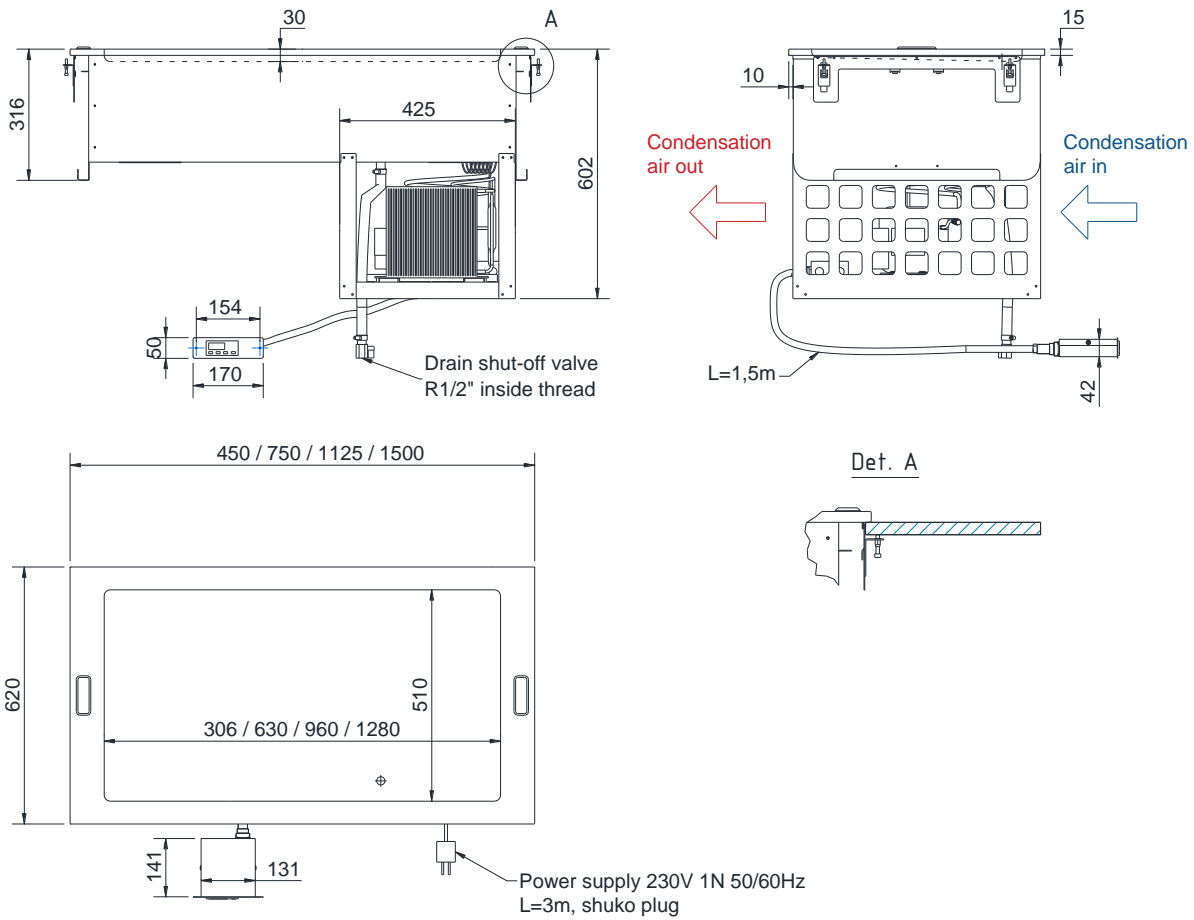

MODEL	CUT-OUT ON TABLE TOP mm
D-I 04 T	435 x 604
D-I 07 T	735 x 604
D-I 11 T	1110 x 604
D-I 15 T	1485 x 604

TECHNICAL DATA				
Model	D-I 04 T	D-I 07 T	D-I 11 T	D-I 15 T
External dimensions w x d x h mm	450x620x602	750x620x602	1125x620x602	1500x620x602
Temperature range °C	+2...+15	+2...+15	+2...+15	+2...+15
Electrical connection V, Hz	230 1N, 50/60	230 1N, 50/60	230 1N, 50/60	230 1N, 50/60
Connected load kW	0,25	0,25	0,25	0,25
Enclosure class	IP44	IP44	IP44	IP44
Type of refrigerant, charge g, GWP	R290, 100, 3	R290, 125, 3	R290, 150, 3	R290, 150, 3
tCO ² -ekv	0,00030	0,00038	0,00045	0,00045
Net weight kg	28	33	39	45
Unit volume m ³	0,3	0,5	0,7	1,0
Unit dimensions mm				
height	770	770	770	770
depth	800	800	800	800
width	480	770	1150	1530

Due to continuous product development we reserve the right to technical changes without notice.

