

## TECHNICAL DATA - MARINE

### Refrigerated drawers and cabinets for drinks

The range of cold units includes various types of refrigerated drawers, cabinets and worktops. Thanks to the flexible modular construction, they are easy to combine to create a customised food service system that best suits personal requirements. All units are made of stainless steel and comply with the hygiene standards for professional kitchens.



#### GENERAL

- Products are designed for the storage of cold beverages
- All surfaces are made of stainless steel
- Ø63mm adjustable marine feet, with a height adjustment range of -20/+40mm
- GN- and bottle basket sized cupboards and drawers
- Removable slide rails and PVC plastic magnetic gaskets
- Doors and drawers include a locking latch with a key

#### PERFORMANCE

- The technical features of products are designed to meet the requirements of cold storage in +30 °C ambient temperature. The capacity is verified by laboratory experiments
- The temperature can be adjusted between +5 and +15°C
- The thermostat control includes a digital temperature display
- The ventilated refrigeration module guarantees even temperature distribution

#### TECHNICAL FEATURES

- The units have 50mm thick walls, insulating material polyurethane
- CFC and HCFC free
- Refrigerant is R290
- The refrigeration module is removable without tools and comes with automatic defrost and evaporation of defrost water
- All cold units are CE marked
- Two refrigeration machine options



# Refrigerated drawers and cabinets for drinks, CD serie

- Temperature range: **+5...+15°C** (maximum ambient temperature of +30 °C in cold storage)
- Refrigerator modules: **C1, C2, CH**
- Unit modules: **1, 2**

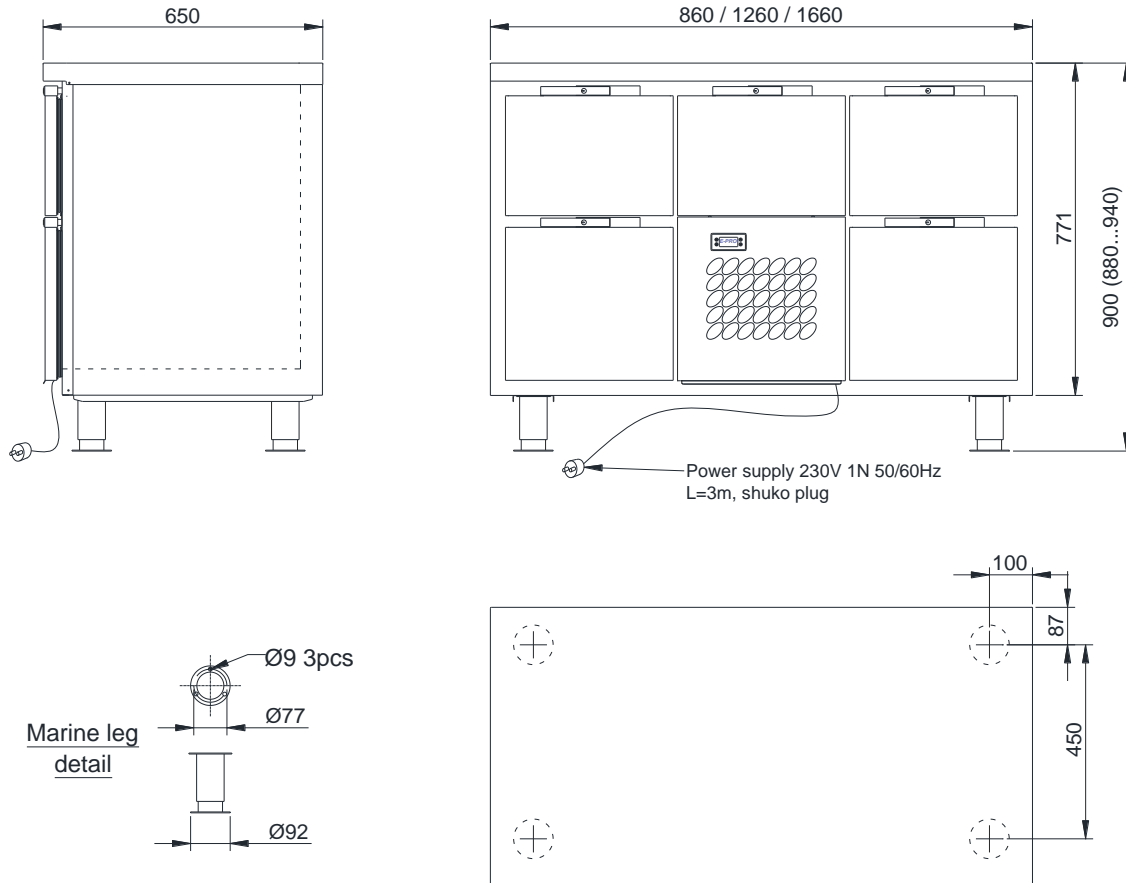

TECHNICAL DATA					
Model	CD-M-2-C2	CD-M-2-C1-2	CD-M-2-C2-2	CD-M-2-C1-2-2	CD-M-2-CH-2-2
External dimensions w x d x h mm	860x650x900	1260x650x900	1260x650x900	1660x650x900	1660x650x900
Temperature range °C	+5...+15	+5...+15	+5...+15	+5...+15	+5...+15
Internal volume dm <sup>3</sup>	242	392	392	542	542
Type of refrigerant, charge g, GWP	R290, 150, 3	R290, 150, 3	R290, 150, 3	R290, 150, 3	R290, 150, 3
tCO <sup>2</sup> -ekv	0,00045	0,00045	0,00045	0,00045	0,00045
Electrical connection V, Hz	230 1N, 50/60	230 1N, 50/60	230 1N, 50/60	230 1N, 50/60	230 1N, 50/60
Connected load kW	0,25	0,25	0,25	0,25	0,50
Enclosure class	IP44	IP44	IP44	IP44	IP44
Net weight kg	94	123	123	153	161
Unit volume m <sup>3</sup>	0,7	1,0	1,0	1,3	1,3
Unit dimensions mm					
height	1050	1050	1050	1050	1050
depth	750	750	750	750	750
width	900	1300	1300	1700	1700

Due to continuous product development we reserve the right to technical changes without notice.



# Refrigerated cabinets for drinks, CDB2 serie

- Temperature range: **+5...+15°C** (maximum ambient temperature of +30 °C in cold storage)
- Refrigerator modules 860 and 1260mm wide model: **C1, CH**
- Refrigerator modules 1660mm wide model: **CH**
- Unit modules: **1**

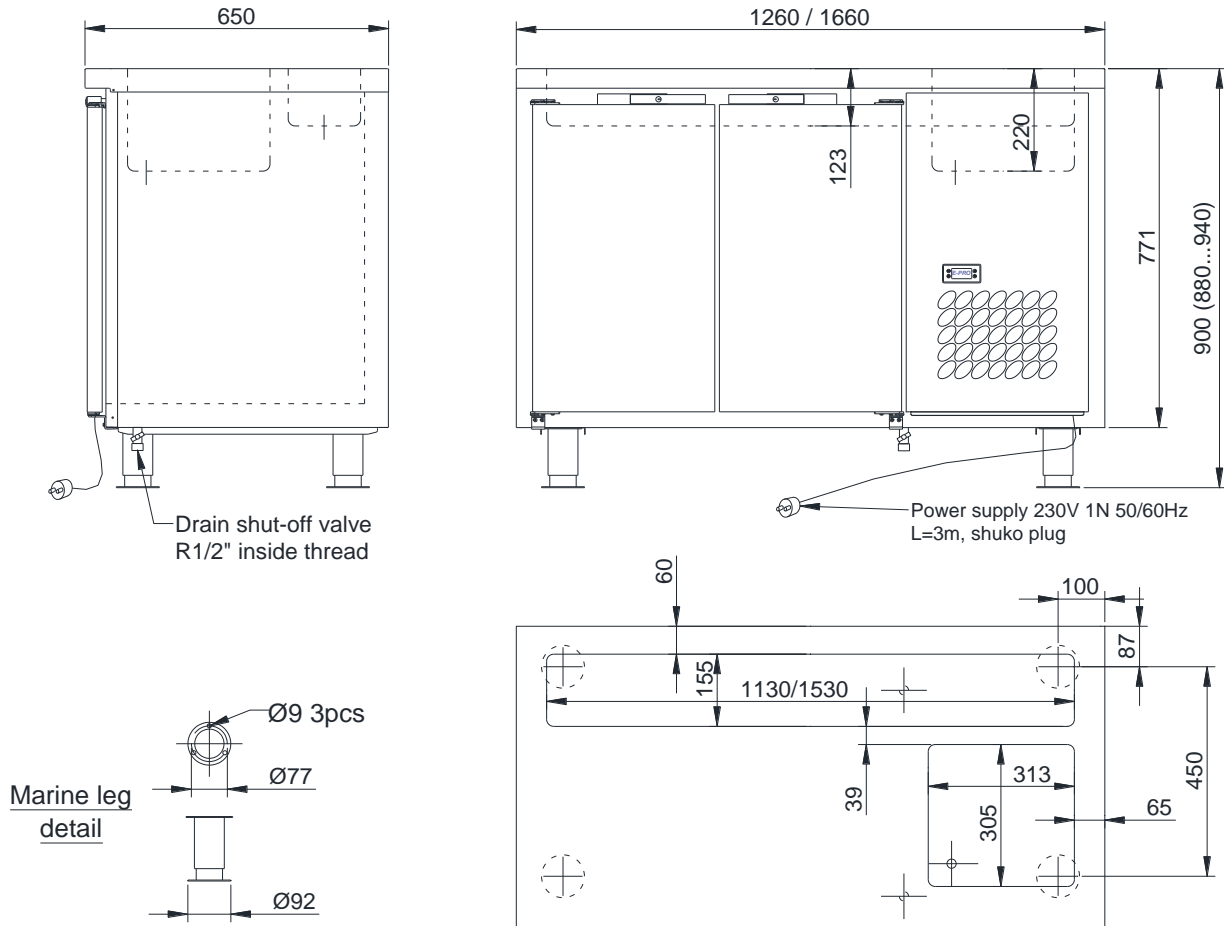

TECHNICAL DATA		
Model	CDB2-M-1-1-C1	CDB2-M-1-1-1-CH
External dimensions w x d x h mm	1260x650x900	1660x650x900
Temperature range °C	+5...+15	+5...+15
Net volume dm <sup>3</sup>	392	542
Type of refrigerant, charge g, GWP	R290, 150, 3	R290, 150, 3
tCO <sup>2</sup> -ekv	0,00045	0,00045
Electrical connection V, Hz	230 1N, 50/60	230 1N, 50/60
Connected load kW	0,25	0,50
Enclosure class	IP44	IP44
Net weight kg	115	153
Unit volume m <sup>3</sup>	1,0	1,3
Unit dimensions mm		
height	1050	1050
depth	750	750
width	1300	1700

Due to continuous product development we reserve the right to technical changes without notice.



## MODULES

### Refrigerator modules CD and CDB2 serie

- C1** Refrigerator module 250W without drawer, temperature range +5...+15°C
- C2** Refrigerator module 250W with a drawer sized for a bottle basket, locking latch with key, temperature range +5...+15°C. Not available in CDB2 serie.
- CH** Refrigerator module 500W without drawer, temperature range +5...+15°C

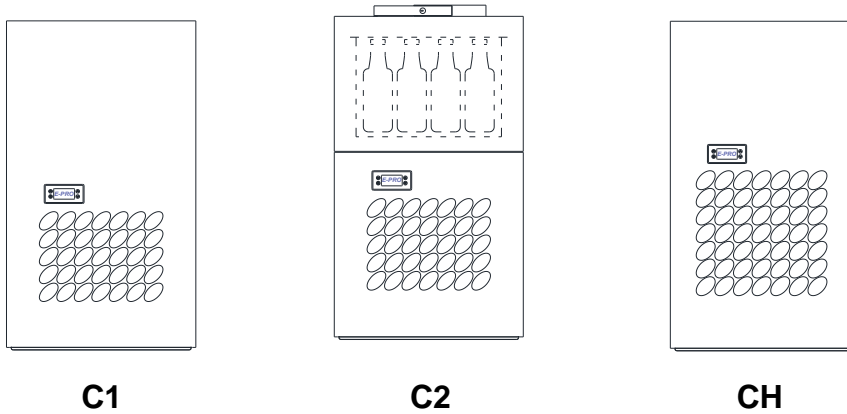

### Unit modules

- 1** Cupboard with a closed door, locking latch with key, two removable shelves and seven pairs of removable shelf brackets
- 2** Two drawers for bottle baskets and locking latches with key. S/s bottle boxes are included. Not available in CDB2 serie

