

TECHNICAL DATA - MARINE

Undercounter cabinet

The range of marine neutral furniture includes various types of tables, cabinets, shelves, trolleys and racks. Thanks to the flexible modular construction they are easy to combine to create customised solutions that meets all requirements. All units are made of stainless steel and comply with the hygiene and other standards for professional kitchens.



GENERAL

- Easy to clean stainless steel construction
- Single and double door options
- Marine locking latch with a key lock
- Height adjustable shelf
- Special executions and sizes available on request
- Wide range of accessories

TECHNICAL FEATURES

- Double body and doors s/s t=0,80mm
- Detachable shelves s/s t=1,00mm
- Welded construction
- Adjustable legs with bolt holes
- S/s brush exterior

Undercounter cabinet single door

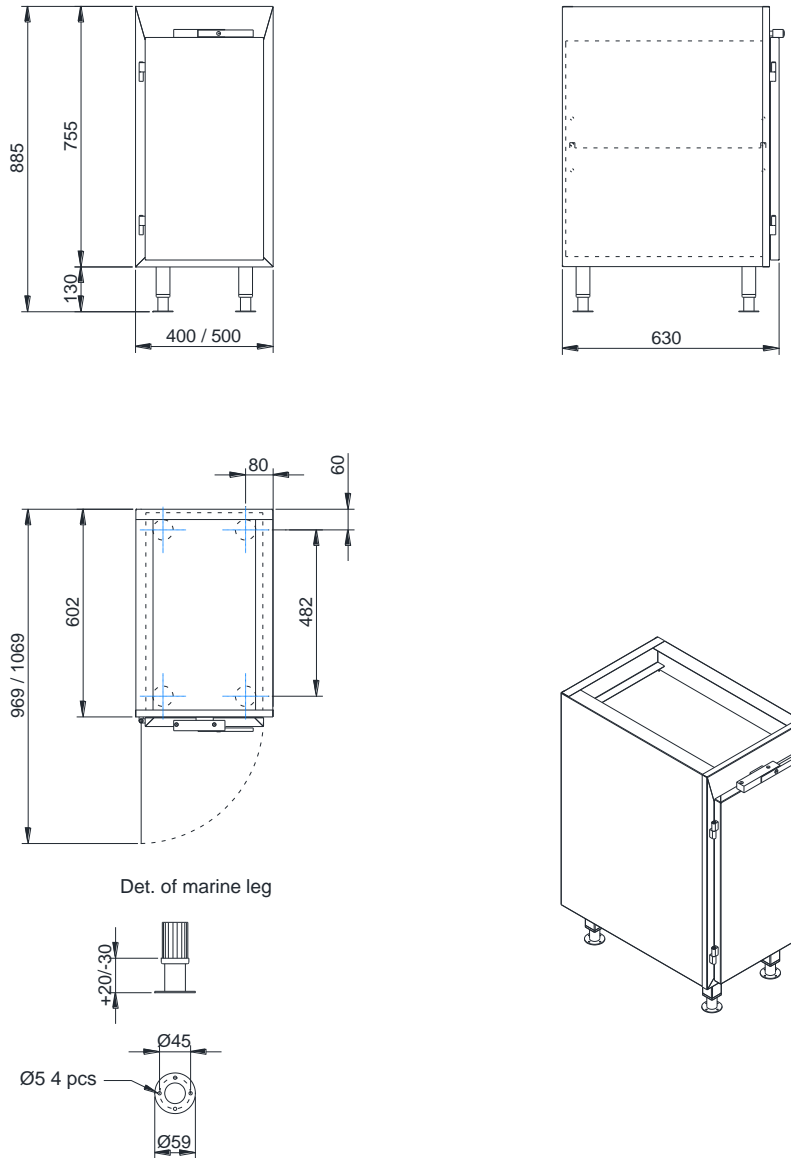

Left hinged version shown

| TECHNICAL DATA | | | | |
|----------------------------------|--------------|--------------|--------------|--------------|
| Model | N-025L-4x6,3 | N-025R-4x6,3 | N-025L-5x6,3 | N-025R-4x6,3 |
| External dimensions w x d x h mm | 400x630x885 | 400x630x885 | 500x630x885 | 500x630x885 |
| Hinges | left | right | left | right |
| Net weight kg | 28 | 28 | 31 | 31 |
| Internal volume dm ³ | 126 | 126 | 163 | 163 |
| Unit volume m ³ | 0,32 | 0,32 | 0,39 | 0,39 |
| Unit dimensions mm | | | | |
| height | 1035 | 1035 | 1035 | 1035 |
| depth | 680 | 680 | 680 | 680 |
| width | 450 | 450 | 550 | 550 |

Due to continuous product development we reserve the right to technical changes without notice.



Undercounter cabinet double door

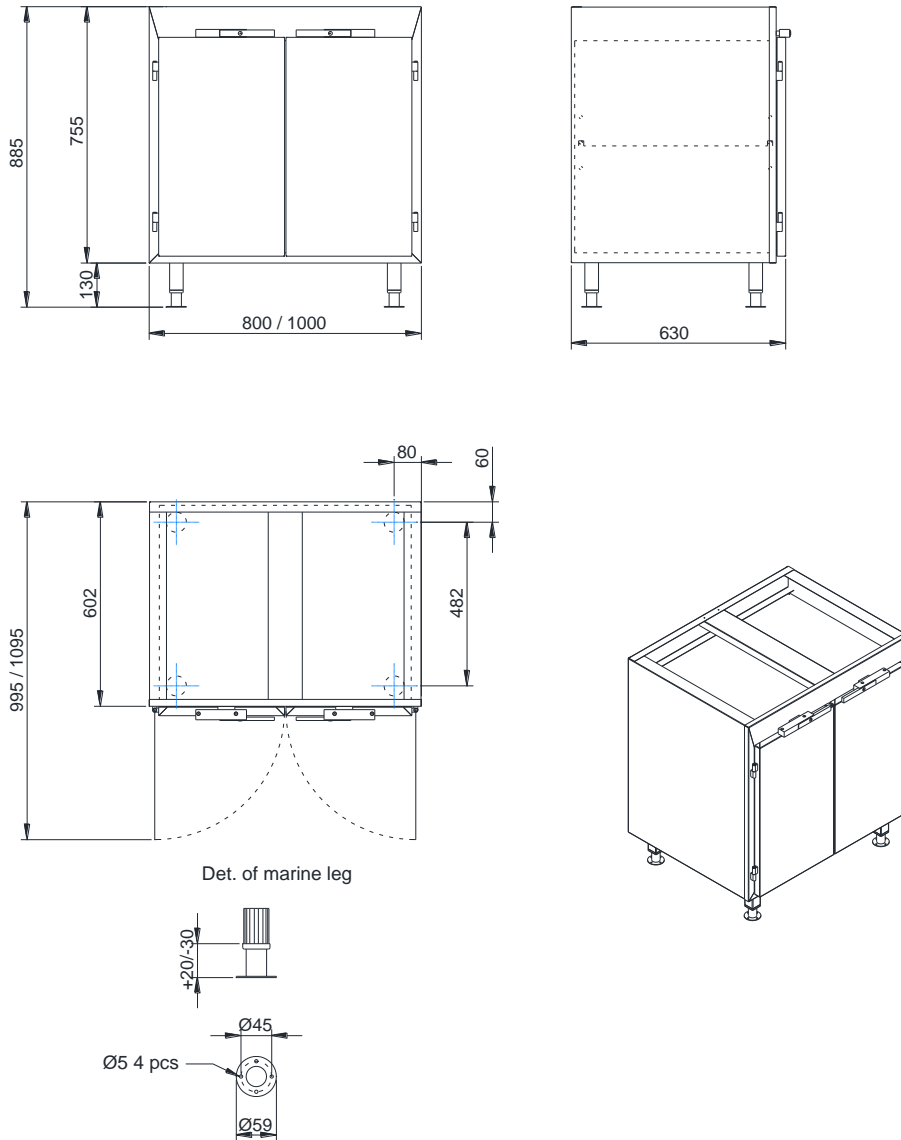

| TECHNICAL DATA | | |
|----------------------------------|--------------|---------------|
| Model | N-025D-8x6,3 | N-025D-10x6,3 |
| External dimensions w x d x h mm | 800x630x885 | 1000x630x885 |
| Net weight kg | 43 | 46 |
| Internal volume dm ³ | 274 | 311 |
| Unit volume m ³ | 0,60 | 0,74 |
| Unit dimensions mm | | |
| height | 1035 | 1035 |
| depth | 680 | 680 |
| width | 850 | 1050 |

Due to continuous product development we reserve the right to technical changes without notice.

